



**PROTECT AND BEAUTIFY YOUR INSTALLATIONS**

# REMOVAL AND REPLACEMENT OF OLD JOINTING PRODUCTS

This brochure is a guide to revitalize landscaping project by replacing current jointing product. Here are instructions to successfully complete a project in **5 easy steps**. **Safety equipment: Safety glasses, waterproof apron & rain overalls**

## SUGGESTED TOOLS



Pressure washer equipment



Quarter-turn hose valve



Street broom



Soap spray nozzle



Shovel



High pressure industrial hose



Turbo nozzle for pressure washer



Tarp



5 Gallon bucket

## STEP 1: PROTECTING THE SURROUNDINGS

- **Cover** adjacent surfaces that are not to be cleaned by using tarps. Move away items that can be displaced.



- **Rinse** all surfaces surrounding the installation thoroughly (siding, flowers, shrubs, mulch beds, windows, lawn, outdoor furniture, fixtures). Pour enough water so the surface remains wet throughout the process. Rinse as often as necessary throughout the process.



## STEP 2: WATERING THE JOINTING MATERIAL TO SOFTEN IT

- **Saturate** all pavers working from high to low elevations.
- This will start softening the polymeric sand and make it easier to remove.
- Let water soak in for a few minutes.







- Before installing the new jointing product, now would be a good time to clean localized stains. Find more information in the MAINTENANCE OF A CONCRETE PAVER INSTALLATION brochure.
- Select one of the jointing products offered by Techniseal.
- Follow the instructions in our Technical Data Sheet (TDS) available on our website: [techniseal.com](http://techniseal.com).

# IT ALL STARTS WITH THE



	 <p><b>THE SMART CHOICE FOR YOUR EVERYDAY INSTALLATIONS</b></p>	 <p><b>THE ONLY REAL NO HAZE NO DUST ALTERNATIVE</b></p> <p><b>HIGH-PERFORMANCE JOINTING SAND VALUED BY TOP INSTALLERS</b></p>	 <p><b>THE FIRST POLYMER-BASED JOINTING SAND SPECIFICALLY DESIGNED FOR PORCELAIN PAVERS</b></p>
<b>Specially Designed for:</b>	Optimal jointing of interlocking pavers	High performance, multi-purpose jointing product	Flagstone, natural stone, cobblestone, and more. Projects where mechanical compaction is not required or traditionally not used.
<b>Project type:</b>	Residential projects Pedestrian and low-traffic areas such as driveways and patios	For residential, commercial, industrial and public projects For high-humidity areas with heavy or no slope and high traffic areas	For residential, commercial, industrial and public projects The true alternative to traditional sand and stone dust
<b>Ideal for:</b>	Interlocking pavers	Concrete, wet-cast, textured or clay pavers False joints	Flagstone, concrete, cobblestone, high-traffic areas False joints
<b>Also used for:</b>		Porcelain pavers <sup>1</sup>	Porcelain pavers <sup>1</sup>
<b>Mechanical Compaction:</b>	Mandatory	Mandatory	Not mandatory (for residential) Mandatory (for jointing)
<b>For joints from:</b>	Ideal for narrow joints from 1/16"-3/8"	Ideal for joints from 1/16"-1"	Ideal for wide joints from 1/2"-4"
<b>Intersecting spaces up to:</b>	1"	2"	4"
<b>Main Colors:</b>	Grey and Tan (colors vary by region)	Black, Grey, Ivory, and Tan (colors vary by region)	Grey and Tan (colors vary by region)

<sup>1</sup> Refer to NextGel™ PORCELAIN, a dedicated solution for porcelain pavers  
<sup>2</sup> Refer to NOCO™ and STORM™, dedicated solutions for natural stone

# EASY | FAST | CLEAN

## RIGHT JOINTING PRODUCT



**NOCO™**  
**NO COMPACTION**

**POLYMERIC JOINTING PRODUCT  
SPECIALLY DEVELOPED FOR FLAGSTONES**

For natural stone  
Mechanical compaction is either not possible or not recommended to be used

For residential, commercial, industrial and public projects  
Ideal for use with mortar, stone dust and polymeric jointing sand

For wet and wet-cast pavers, imitation of natural stone  
Ideal for textured surfaces, large slabs

For joints >1/4")  
For joints ≤1/4")

For joints from 1/4"-2"

Colors vary by region)

**NextGel PORCELAIN**  
**PAVER JOINTING SAND**

**A FASTER & CLEANER SOLUTION  
FOR GROUTING PORCELAIN PAVERS**

Porcelain pavers

Residential, commercial, industrial and public projects

Porcelain pavers  
Convenient 25 lb bag covers 100 sq. ft

Calibrated natural stone such as granite, marble, travertine pavers<sup>2</sup>

Mandatory

Ideal for joints from 1/16" to 1/2"

1"

Black, Grey, Ivory, and Tan

**STORM**  
**NO COMPACTION**

**A JOINTING COMPOUND THAT WORKS  
UNDER WET OR DRY WEATHER CONDITIONS**

Multi-weather  
Permeable installations. A porous draining base is required for proper installation

For residential, commercial, industrial and public projects

Natural stone, concrete, wet-cast, textured or clay pavers  
large slabs

Porcelain pavers<sup>1</sup>

Not mandatory

Ideal for wide joints from 1/8"-2"

4"

Black, Grey, Ivory, and Tan

## PROPER LEVELING IS CRITICAL

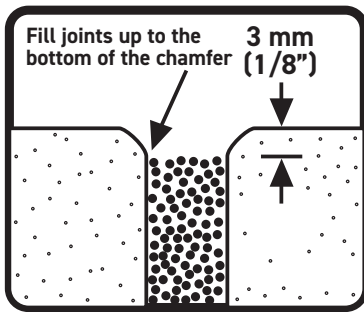

Joints should **NEVER** be flush with the paver surface. Allow 3 mm (1/8") below the paver surface or as high as the bottom of the chamfer. This allows the water to percolate down the joint instead of flowing over it. Tip: Use the leaf blower to adjust the height before the wetting step.



## THE IMPORTANCE OF COMPACTION

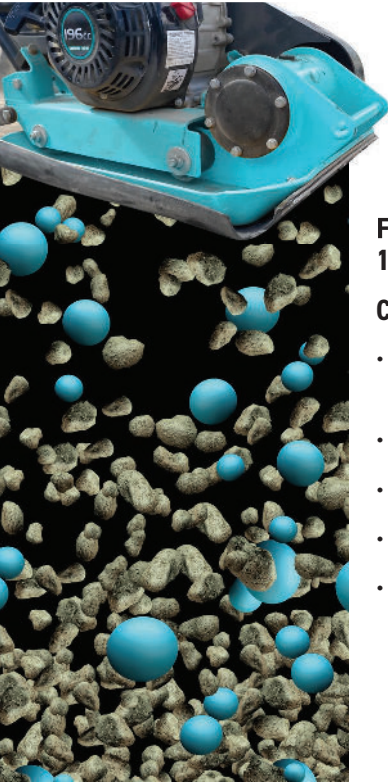

**FACTS:** The right grading allows Techniseal Jointing Products to be **12% denser** (weight/volume) than ungraded sand.

### Compaction will:

- **Increase** the quantity and quality of **bonding contacts** between aggregates
- **Reduce water absorption** by over 60%, ensuring proper polymerization
- Significantly **reduce drying time**
- Reduce the risk of **washing away the polymers** while wetting the sand
- **Increase the durability** of the joints



## WETTING THE POLYMERIC JOINTING SAND

- Critical step to obtain optimal results.
- Use only the "Shower" setting on a regular garden hose nozzle or as specified in the jointing product TDS. Don't mist, don't get creative!
- Follow specific wetting instructions for each jointing product (refer to TDS).
- Polymeric Jointing Sands: If product is activated at 75% or more of its depth, stop watering. If activated at less than 75%, more water is required. Recheck after 30 seconds. Avoid overwatering, as this will significantly lengthen the curing time and may compromise product performance.

**Using a utility knife,  
check joint for  
correct watering**



### STEP 3: CLEANING AND BLOWOUT

- Using a concrete turbo nozzle or rotary nozzle, **pressure wash** all the pavers to clean surfaces and remove joint contents (down to a minimum of 1½ to 2"). For a porcelain installation, entire joints need to be removed. Hot water could also help the process.
- It is preferable to set the pressure of your pressure washer to 1500 psi to prevent damage to the pavers. Follow the manufacturer's recommendations.
- **Always keep an angle of 45 degrees** and keep the pressure washing wand 12 to 18 inches from the surface to avoid any irreversible scarring damage to the pavers.
- If the jointing product is harder to remove in some areas, slowly increase the pressure, still taking care not to damage the surface of the pavers.
- Be sure to work in a controlled fashion, one square section at a time, working from highest elevation to lowest, blowing away from house towards grass.
- Also, be sure to clean out between the last row of pavers and edge restraints.
- Use nozzle to slice back sod where applicable to reveal the edge of pavers and for a crisp look.
- As joint content piles up on surface (larger projects), use a bucket and shovel to remove excess and dump appropriately.
- **Rinse** all surfaces again to dislodge the sand and soil particles that may have been thrown onto adjacent surfaces.
- **Rinse** all pavers working from **high to low** elevations before shutting down washer.



### STEP 4: ALLOW INSTALLATION TO DRY COMPLETELY

- A wet foundation or surface will cause the activation of the jointing product before compaction and activation. It may also clog the sides of the pavers and prevent the product from filling the entire joints in depth.
- It is imperative to allow the installation to **dry completely** before installing the new jointing product.
- Temperature must be above 0 °C (32 °F) for the following 24 to 48 hours.
- Allow a **minimum of 24 to 48 hours** in dry conditions (depending on the overall temperature and humidity).



### STEP 5: RELEASING OLD JOINTING PRODUCT

- If necessary, run a plate compactor or a paver roller compactor over your paver installation to release any jointing product still hooked to the side of the pavers.



 **Techniseal**<sup>®</sup>  
Protect and Beautify

MAINTENANCE OF  
A CONCRETE PAVER  
INSTALLATION

PROTECT AND BEAUTIFY YOUR INSTALLATIONS

## QUESTIONS?



If in doubt, do not hesitate to contact our experienced technical support team, available **Monday to Thursday 8 am to 5 pm (EST), and Friday 8 am to 4 pm (EST).**

TO CONTACT OUR TEAM :

- **Call:** 1 800 465-7325
- **Email:** [service@techniseal.com](mailto:service@techniseal.com)
- Visit [techniseal.com](http://techniseal.com) and fill-in the form in the "Support" section.

341-456/1223

 **Techniseal**<sup>®</sup>

ENJOY YOUR INSTALLATION FOR YEARS TO COME

